

HUROM

Instruction Manual (For Household Use Only / Warranty Included) | H-100S Series

02

Before Reading Manual

1. Read 'Safety Precautions' (p. 2-5) and use the appliance properly.
 2. After reading the manual, keep it in a convenient location for future reference.
 3. Do not use it abroad which has different power supply and voltage.
 4. Any quality improvements is subject to change without notice.
-

CONTENS

02 Safety Precautions	16 How to Assemble: Chamber Set and Main Body
05 Cautions during Operation	17 Using Power Dial / When Screw Stops in Use
06 Parts and Accessories	18 How to Use
08 Component Details	20 Separating and Washing / Disassembling and Washing Silicon Components
12 Assembling Juice Chamber Set	22 Before Requesting for Repair
14 Assembling Ice Cream Chamber Set	23 Product Specifications / Warranty



Safety Precautions

- 01 You should read <Safety Precautions>
- 02 You should follow <Safety Precautions>
- 03 Precautions are classified as follows.



Warning

Violating the labeling requirement, may cause serious injury or death.

- **DO NOT PLUG IN NOR UNPLUG WITH WET HANDS.**

It may cause electric shock or injury.

- **DO NOT USE OTHER THAN 230 V - 240 V AC.**

It may cause electric shock, fire or abnormal performance. If the voltage is different, it may shorten the life of the motor or cause a failure.

03



Safety Precautions

- **PLUG THE POWER CORD CORRECTLY AND FIT IT TIGHTLY INTO A WALL SOCKET.**
It may cause an electric shock or a fire.
- **IF THE POWER CORD IS DAMAGED, IT MUST BE REPLACED BY THE MANUFACTURER'S SERVICE OR SIMILARLY QUALIFIED PERSONS IN ORDER TO AVOID A HAZARD.** If the power cord is damaged, it may cause electric shock or fire.
- **NEVER DISASSEMBLE CHAMBER SET PARTS OR INSERT ALIEN SUBSTANCES INTO THE JUICE OUTLET AND PULP OUTLET WHILE THE JUICER IS RUNNING.**
It can cause injury, accident, or trouble
- **WHEN THE POWER CORD, WIRE IS BROKEN OR DAMAGED OR THE PLUG-IN PART BECOMES LOOSE, DO NOT OPERATE THE MACHINE.**
It may cause electric shock, fire or injury.
- **DO NOT WET OR SPLASH WATER ON THE MAIN BODY.**
Be careful not to let any liquids or other substances get into the switch on the appliance.
- **DO NOT OPERATE THE POWER DIAL WITH WET HANDS.**
It may cause an electric shock or fire.
- **FOR SAFETY, GROUND THE APPLIANCE. (MAKE SURE TO USE THE OUTLET WITH GROUND CONNECTION.) DO NOT GROUND TO GAS PIPE, PLASTIC WATER PIPE, TELEPHONE LINE, AND SO FORTH.**
It could cause electric shock, fire, malfunction or explosion.
- **NEVER DISASSEMBLE THE CHAMBER SET DURING OPERATION NOR INSERT FINGERS, FOREIGN OBJECTS SUCH AS FORKS, SPOONS, ETC. INTO HOPPER CHUTE OR JUICE OUTLET.** It may cause injury, accident or failure.
- **APPLIANCES CAN BE USED BY PERSONS WITH REDUCED PHYSICAL, SENSORY OR MENTAL CAPABILITIES OR LACK OF EXPERIENCE AND KNOWLEDGE IF THEY HAVE BEEN GIVEN SUPERVISION OR INSTRUCTION CONCERNING USE OF THE APPLIANCE IN A SAFE WAY AND IF THEY UNDERSTAND THE HAZARDS INVOLVED. CHILDREN SHALL NOT PLAY WITH THE APPLIANCE. CLEANING AND USER MAINTENANCE SHALL NOT BE MADE BY CHILDREN. THIS APPLIANCE SHALL NOT BE USED BY CHILDREN. KEEP THE APPLIANCE OUT OF REACH OF CHILDREN.**
- **DO NOT USE THE PRODUCT WHILE WEARING OR CARRYING ITEMS WITH MAGNETIC FORCE (E.G., MAGNETIC BRACELETS, ETC.).**
Placing objects with magnetic force around the product may lead to malfunctions.



Caution

Violating the labeling requirement, may cause serious injury or damage to the appliance.

- **DO NOT RUN THE JUICER WHILE THE CHAMBER SET IS NOT ASSEMBLED PROPERLY.** It can cause injury, accident, or trouble.

04 Safety Precautions

- **WHEN DETECTING A GAS LEAK, DO NOT INSERT THE POWER CORD INTO THE OUTLET. OPEN THE WINDOW TO VENTILATE FULLY AND IMMEDIATELY.**
It may cause injury or failure.
- **IF THE SCREW STOPS TURNING, TURN THE POWER DIAL TO [REV] DIRECTION TO TURN THE SCREW IN REVERSE DIRECTION FOR 3~5 SECONDS, AND THEN TURN THE DIAL BACK TO [ON] DIRECTION. IF THE MACHINE CONTINUES TO STOP WHILE RUNNING, IT MAY LEAD TO DAMAGE TO PARTS AND FUNCTIONAL DEGRADATION DUE TO OVERHEATED MOTOR.**
If the problem persists, stop the product and contact Hurom Customer Center.
- **DURING THE OPERATION, DO NOT ATTEMPT TO MOVE THE MAIN BODY, DISASSEMBLE THE CHAMBER SET OR PARTS, OR TRY TO LOCK THEM.** It may cause an injury or a failure. If any action is needed, switch off and unplug the power cord first.
- **MAKE SURE NO ALIEN SUBSTANCES GET INTO THE HOPPER OTHER THAN INGREDIENTS WHEN USING THE JUICER.**
It can cause damage or breakage.
- **PLACE THE APPLIANCE ON A FLAT AND STABLE SURFACE.**
It may cause injury or failure.
- **DO NOT OPERATE THE APPLIANCE FOR MORE THAN 30 MINUTES AT A TIME.**
It may cause a motor failure due to overheating. Cool it down sufficiently about 5 minutes and operate it again.
- **DO NOT ALLOW A SEVERE SHOCK TO THE APPLIANCE NOR DROP IT.**
It may cause electric shock, fire or damage.
- **IF THE APPLIANCE GIVES OFF AN UNPLEASANT SMELL, EXCESSIVE HEATING, OR SMOKE, STOP USING THE APPLIANCE IMMEDIATELY AND CONTACT THE LOCAL CUSTOMER CARE CENTER.**
When using a new appliance, it gives off a smell, which disappears naturally over time.
- **ALWAYS UNPLUG THE APPLIANCE AFTER USE. ALWAYS DISCONNECT THE APPLIANCE FROM THE POWER SOURCE IF IT IS LEFT UNATTENDED AND BEFORE ASSEMBLING, DISASSEMBLING OR CLEANING. WHEN UNPLUGGING THE POWER CORD, MAKE SURE TO HOLD THE POWER CORD BY ITS HEAD.**
Pulling the cord to unplug may cause electric shock or fire.
- **DO NOT WASH THE APPLIANCE AT A HIGH TEMPERATURE, 80°C(176°F) OR HIGHER. DO NOT PUT THE APPLIANCE IN A DISHWASHER, A DRYER OR A MICROWAVE ETC.**
It may cause a trouble or a deformation of part.
- **THE MACHINE WEIGHS ABOUT 5.7kg. WHEN YOU ARE MOVING THE MACHINE, MAKE SURE YOU HOLD THE MAIN BODY TIGHTLY WITH BOTH HANDS.**
When you hold the machine by the chamber or the side of the main body, the main body may fall and result in injury or malfunction.
- **DO NOT USE HOUSEHOLD PRODUCTS FOR COMMERCIAL PURPOSE.**
Forcing a large amount of ingredients for extraction may damage the parts. Please contact the Customer Service Center for the advice on using the product for commercial purposes.

05 Cautions during Operation

- * **This is a reference about how to trim the ingredients, so if you have allergy please choose your own proper ingredients which agrees with you.**
- * **Ingredients that need attention: Ingredients that can be used for extraction but requires attention for preparation.**
 - For fruits with a hard seed that cannot possibly be chewed with teeth (such as persimmon, apricot, lemon, plum, and peach), make sure the seed is removed before extraction. (If not, it may cause damage or malfunction.)
 - For vegetables with long and tough fibers (such as water parsley and celery), cut them to 3-4cm in length for insertion.
 - Extracting juice from root vegetables (such as ginger, garlic, etc.) in a large quantity at once may lead to damage or malfunction.
 - When you are extracting a large amount, repeat the process, 'Extract 1kg, disassemble, and wash'
- * **Ingredients to Avoid: Inserting these ingredients may lead to damage or malfunction.**
 - Ingredients that are not for extracting juice such as sesame seeds, coffee beans, tree barks, Chinese pepper, etc.
 - Boiled ingredients (potato, sweet potato, sweet pumpkin, chestnut), loach, eel, shrimp, marsh snail, squid, salted fish, etc.
 - Fruits pickled in liquor, honey, sugar, etc. (such as grapes, Korean raspberry, mulberry, etc.) and enzymes (herbacea, rock pine, etc.)
 - Ingredients that does not produce juice according to the characteristic of the ingredients such as linden, aloe, cactus, acorn, etc. (Contact Hurom Customer Center and ask us about the ingredients to use for extraction. We will answer you in detail.)
 - Do not use the machine for crushing cereals.
 - Ice prepared by freezing water (shall be avoided for both juice strainer and ice cream strainer)
- * **If ingredients have withered after prolonged storage in the refrigerator, they may produce less or very little amount of juice.**
- * **We recommend you to drink green vegetable juice and fruit juice immediately after extraction rather than keeping them for long time.**
- * **Do not re-squeeze pulp discharged through the pulp outlet.**
- * **Do not idle the product before inserting ingredients.**
- * **Do not insert too many ingredients at once.**
 - If you insert an excessive amount of ingredients of thick ingredients, the unit may stop.
- * **Do not use for more than 30 minutes in a continuously.**
 - It may cause a failure due to the overheating of the motor.
When using the appliance continuously, stop for 5 minutes after every 30 minutes of use.
- * **Never insert chopsticks or spoon into pulp outlet during the operation.**
 - Inserting chopsticks and the like may cause damage to parts and personal injury.
- * **Do not press the ingredients with anything except the pusher.**
 - It may stick to the screw and cause injury and failure.
- * **Do not operate the power dial with a wet hand**
 - It can cause electric shock, short circuit, or fire. Do not stain the power dial and its proximity with alien substances.
- * **If you are extracting 350ml of juice or more at once, open the juice cap to discharge the juice for every 350ml. If you are extracting a large amount of juice, open the lift lever frequently to discharge pulp.** The pressure inside the chamber may increase and make it impossible to open the chamber cover or cause damage.
- * **If there is any water or juice on the main body or standing in any area of the machine, make sure you wipe it with a dry cloth before use.**
- * **For frozen fruits, use the ice cream strainer only. Do not use the product for crushing the ice frozen from water and other ingredients or for mincing.** It may lead to damage or malfunction.
- * **If you do not wash immediately after use, it may be caked with pulp, which makes it difficult to disassemble and wash or may become the cause of performance degradation.**

06 Component Guide (Chamber Set)

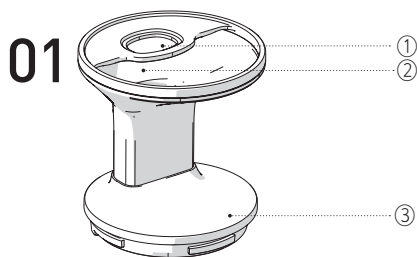

Hopper

- ① Upper hopper chute
- ② Side hopper chute
- ③ Assembly Guide ▼

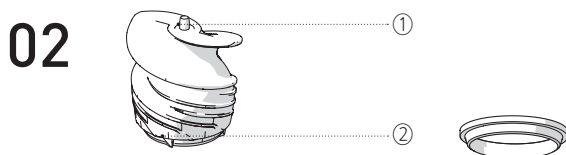

Screw

- ① Screw Axis
- ② Screw Packing

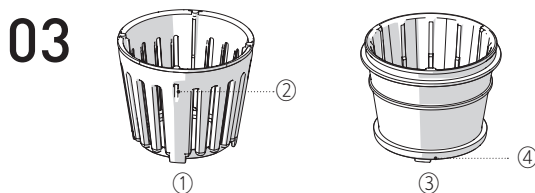

Inner Strainer

- ① Inner Strainer
- ② Inner Strainer Binding Points
- ③ Ice Cream Strainer
- ④ Ice Cream Strainer Guide Bumps

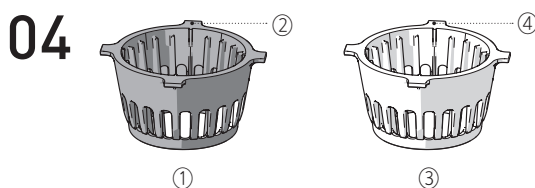

Outer Strainer

- ① Juice Strainer (Black)
- ② Juice Strainer Wing (J)
- ③ Smoothie Strainer (orange)
- ④ Smoothie Strainer Wing (S)

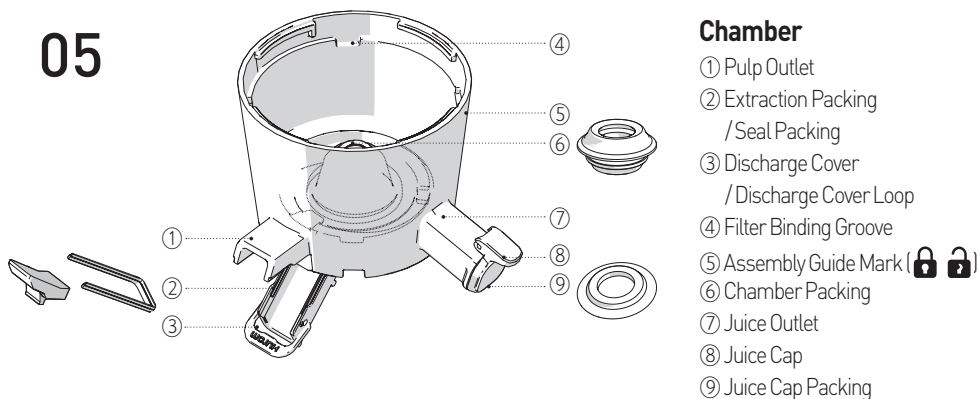

Chamber

- ① Pulp Outlet
- ② Extraction Packing / Seal Packing
- ③ Discharge Cover / Discharge Cover Loop
- ④ Filter Binding Groove
- ⑤ Assembly Guide Mark (🔒 🔒)
- ⑥ Chamber Packing
- ⑦ Juice Outlet
- ⑧ Juice Cap
- ⑨ Juice Cap Packing

07 Component Guide (Main Body, Other Components)

06

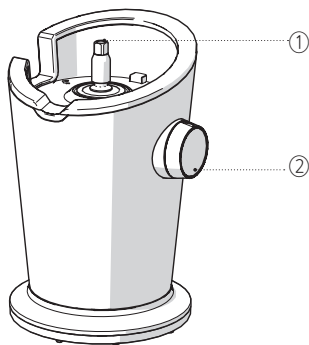

Base

- ① Motor Spin
- ② Power Dial

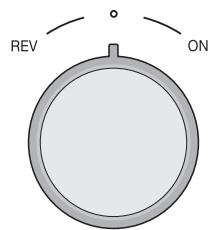

07

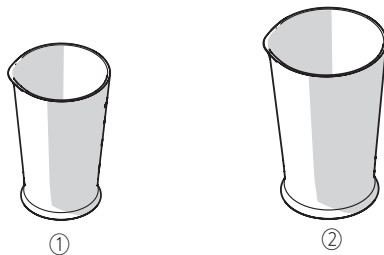

Container Set

- ① Juice Container
- ② Pulp Container

08

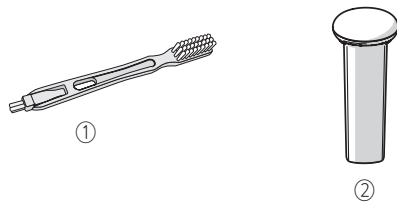

Accessories

- ① Cleaning Brush
- ② Pusher

08 Component Details

01 / Hopper

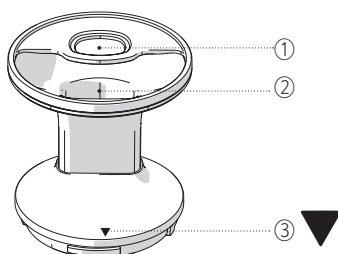

- ① **Upper hopper chute:** Use this to insert long and narrow vegetables such as celery and carrot.
- ② **Side hopper chute :** Use this to insert cherry tomato, grapes, and diced fruits and vegetables
- ③ **Assembly Guide Mark on Hopper :** Marks to check the assembly with the chamber.
Parts must fit properly in order to work.

02 / Chamber

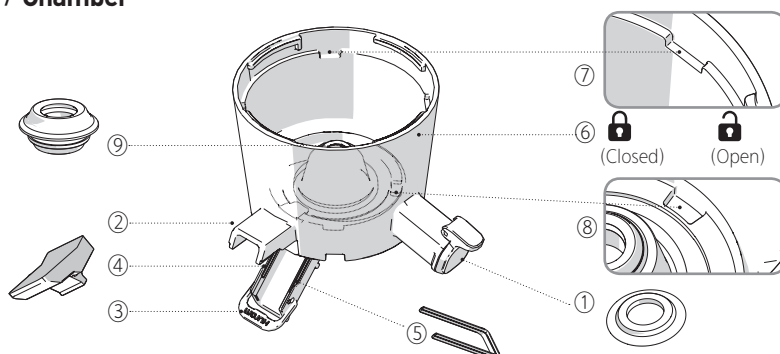

- ① **Juice Cap / Juice Cap Packing:** A cap for preventing juice from being discharged in case of extraction. The juice cap packing is assembled inside the juice cap.
- ② **Pulp / Ice Cream Outlet:** An outlet for discharging extraction pulp or ice cream.
- ③ **Discharge Cover / Discharge Cover Loop:** The lower part of the pulp outlet.
If not properly assembled, it will leak juice.
- ④ **Extraction Packing:** This packing is assembled in the discharge cover.
If not properly assembled, it will leak juice.
- ⑤ **Seal Packing:** This packing is assembled in the discharge cover.
If not properly assembled, it will leak juice.
- ⑥ **Chamber Assembly Guide Mark:** This guide mark is used when assembling with the hopper.
Proper assembly ensures normal operation.
- ⑦ **Filter Binding Groove:** Chamber grooves that fix the filter wings.
- ⑧ **Chamber Bottom Groove:** Grooves for fixing the ice cream strainer and inner filter.
- ⑨ **Chamber Packing:** Packing in the middle of the chamber. If not properly assembled, it will leak juice.

09 Component Details

03 / Juice Strainer (Black)

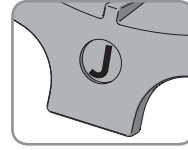
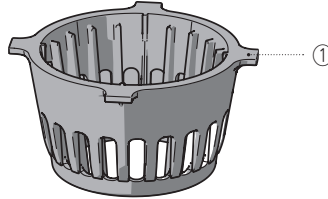

① **Juice Strainer Wing**
:Wings for fixing chamber and strainer. Fit the winter wings to the grooves on the chamber.

- Use this to extract juice from fruits containing plenty of flesh, ordinary vegetables / fruits. (Use smoothie strainer for soft fruits)
- Classification of strainer: Dark black in color which is darker than smoothie strainer. You will find the strainer distinguishing mark on the wing [J].
- You can extract juice from common fruits and vegetables such as apple, pear, and broccoli with the juice strainer. Some ingredients need to be prepared carefully. Please check how to prepare them according to the following list.

Root Vegetables	Fresh Sweet Potato, Ginger, Carrot, Fresh Potato, Garlic, Dandelion, etc.	Wash the ingredients thoroughly in running water to remove foreign matters such as the soil. For ingredients containing plenty of fiber such as ginger, remove the peel and cut it into slices, and insert it slowly. As for other root vegetables, cut them to 3~4cm before use. When you are extracting a large amount, repeat the process, 'Extract 1kg, disassemble, and wash'
Leaf/Stem Vegetables	Wheat Sprout, Chives, Kale, Water Parsley, Cactus, Celery, Cabbage, Spinach, etc.	Make sure the ingredients are cut to 3~4cm. As for thin and narrow vegetables such as wheat sprouts and chives, put them in handfuls so that the ingredients would not scatter. cut them to 3~4cm before use. When you are extracting a large amount, repeat the process, 'Extract 1kg, disassemble, and wash' * Spinach produces a lot of bubbles when extracted by itself, making it difficult to extract juice. Only use a small amount for mixed juice.
Fruits with Thick Peel	Pomegranate, etc.	Remove the peel and cut the flesh into the sizes that fit the hopper inlet. Remove seeds that cannot be chewed with teeth.
Fruits with Large Seed	Persimmon, Apricot, Peach, etc.	For fruits and vegetables containing a large and hard seed that cannot be chewed with teeth such as peach, remove the seed and only use the flesh. Cut them to sizes that would fit the hopper inlet.
Nuts and Beans	Almonds, Walnut, Soaked Beans, etc.	Do not use nuts by themselves but with fruits and vegetables. Insert fruit and vegetable mixture first and then gradually add nuts. As for beans, soak them in water fully for a day before use. To make bean juice, put water and beans by the ratio of 1:1.
Juice Strainer Prohibited (Soft fruit)	Banana, strawberry, kiwi, tomato, cherry tomato, mango, pineapple, etc.	Do not use the juice strainer for extraction. Use the smoothie strainer.

10 Component Details

04 / Smoothie Strainer (Orange)

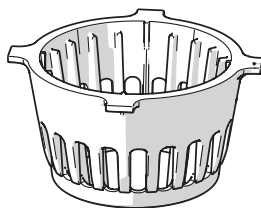

① **Smoothie Strainer Wings:**
These are used to fix the strainer to the chamber. Fit the wings to the grooves of the chamber when putting them together.

- Use this to extract juice from soft fruits and fruits containing plenty of flesh and fiber.
- Classification of Strainer: Smoothie Fileter is light in orange color.
You will find the strainer distinguishing mark on the wing [S].
- Refer to the following table for extractable fruits and the preparation of each ingredient.

Citruses	Grapefruit, Orange, Lemon, etc.	Remove the peel and cut the flesh to the size that would pass through the hopper inlet. Make sure the unchewable seed is removed before inserting ingredients.
Fruits with thick peel	Dragon fruit, Melon, Pineapple, Watermelon, etc.	Remove the peel and cut the flesh to the size that would pass through the hopper inlet. Make sure the unchewable seed is removed before inserting ingredients.
Fruits with seed/ grapes	Soft peach, Soft persimmon, Old apple, Grape, Plum, Cherry, etc.	For fruits with a hard seed that cannot possibly be chewed with teeth and fruits and vegetables with a large seed such as peach, make sure the seed is removed and prepare only the flesh. Cut ingredients to the size that fits the hopper inlet. Separate each grape from the cluster. If the ingredient is too soft, do not extract with the ingredient alone but mix it with another ingredient in a small amount.
Soft fruits and vegetables	Berry, Tomato, Cherry tomato, Pineapple, etc.	Clean thoroughly and cut to sizes that would fit the inlet. For fruits and vegetables with stem, remove the stem.
	Strawberry, Kiwi, Mango, etc.	Remove the peel and stalk. When using a single material to extract juice, insert a piece of hard material such as the vegetable with tough fiber or apple/carrot before inserting soft material.
	Banana	Only add a small quantity to other ingredients to make mixed juice. Remove the peel thoroughly and cut to 3~4cm to fit the inlet.

- * For your reference, choose ingredients carefully if you have allergy.
- * Refer to the ingredient preparation guide, choose the strainer suitable for the ingredient.
The juice might leak or the product may be damaged.

* **Prohibited Ingredients: Inserting these ingredients may lead to damage or malfunction.**

- Ingredients that are not for extracting juice such as sesame seeds, coffee beans, tree barks, Chinese pepper
- Boiled ingredients (potato, sweet potato, sweet pumpkin, chestnut), loach, eel, shrimp, marsh snail, squid, salted fish, etc.
- Fruits pickled in liquor; honey, sugar, etc. (such as grapes, Korean raspberry, mulberry, etc.) and enzymes (herbacea, rock pine, etc.)
- Ingredients that does not produce juice according to the characteristic of the ingredients such as linden, aloe, cactus, acorn, etc. (Contact Hurom Customer Center and ask us about the ingredients to use for extraction. We will answer you in detail.)
- Do not use the machine for crushing cereals.
- Ice prepared by freezing water (shall be avoided for both juice strainer and ice cream strainer)

11 Component Details

05 / Ice Cream Strainer

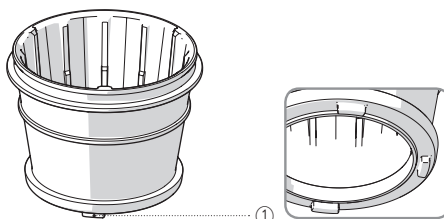

① Guide Bump:

When you set ice cream strainer onto the chamber, use the groove on the chamber and the bump on the strainer as the guides to fit them together completely.

- Used to make slushie, smoothie, and ice cream using frozen fruits.
- Ice cream strainer is used without external strainer.
- Dice fruits to 2cm and freeze them thoroughly before use.
- For fruits with a hard seed that cannot be chewed with teeth, make sure the seed is removed before use.
- Do not use the machine for crushing ice frozen from water and other ingredients or for mincing.
- The machine may stop if you put too much at once or put a massive chunk. Insert ingredients in a small amount.
- When extracting from slightly thawed fruits, the juice may leak through pulp / ice cream outlet. (This is normal and is not a defect.)
- Refer to the following for extractable fruits and how to prepare them. (Add in small amounts)

Fruits with Thick Peel	Watermelon, Melon, etc.	Remove the peel and cut the flesh into the sizes that fit the hopper inlet and freeze.
Fruits with Seed	Mango, Peach, Grapes, etc.	Use seedless frozen fruits only. For fruits with seeds that cannot be chewed with teeth such as mango, peach, and lemon, make sure the seeds are removed and freeze the fruits beforehand. For grapes, choose the ones without seeds and freeze them before use.
Soft Fruits and Vegetables	Banana, Strawberry, Kiwi, Tomato, Cherry Tomato, etc.	Remove the peel thoroughly for banana and kiwi and cut them to 3-4cm to fit the inlet. For cherry tomato, strawberry, etc., remove the stem and freeze before use.

06 / Power Dial

Turn to left or right to start, stop, or reverse.

[ON]: Start - Used to run the machine to extract juice.

[●]: Stop - Used to stop the machine.

[REV]: Reverse - Used to reduce pressure inside chamber by pushing up the ingredients when the machine stops or too much ingredient was placed.

(Runs only when you hold the dial. Stops when you let go your hand.)

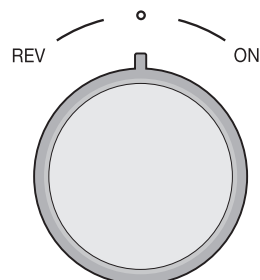

12 Assembling Juice Chamber Set

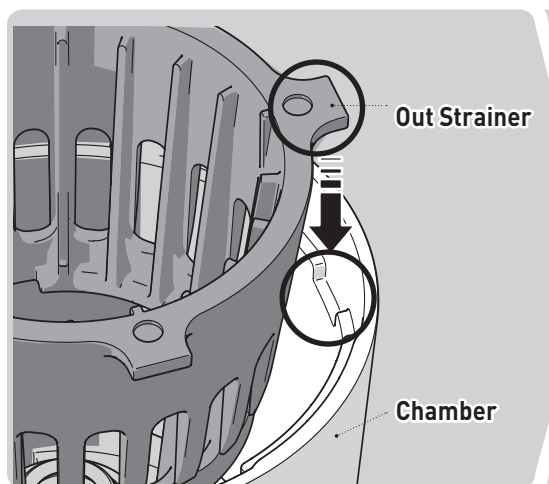
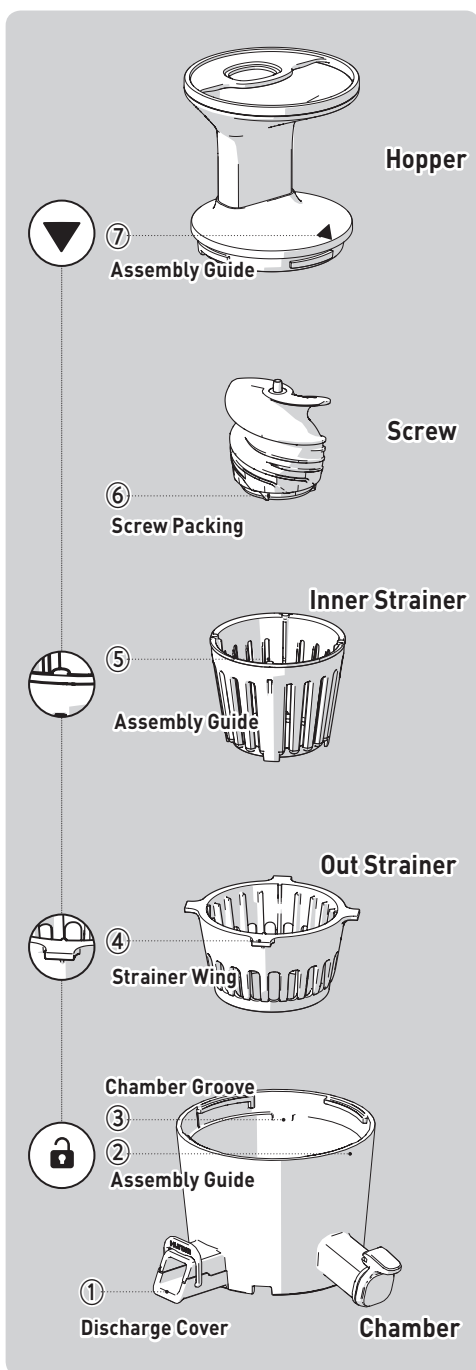

01 Fit the wings of the external strainer (4) to the grooves of the chamber (3).

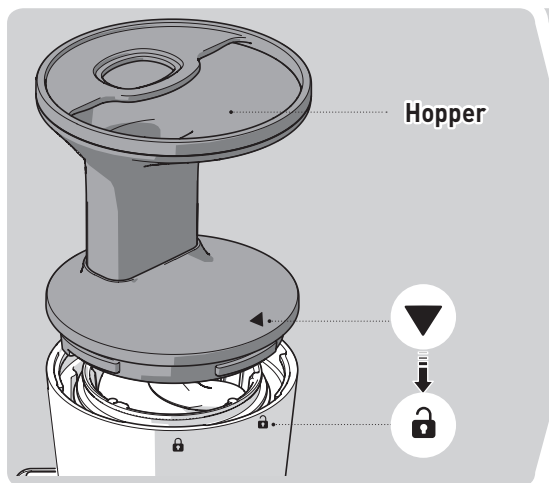

04 Put together the hopper and chamber by matching the mark on hopper [▼] (7) and the mark on the chamber [🔒].
If the inner parts are not assembled properly, the hopper will not close.

13

※ Assembly Guide with Main Body is in p16.

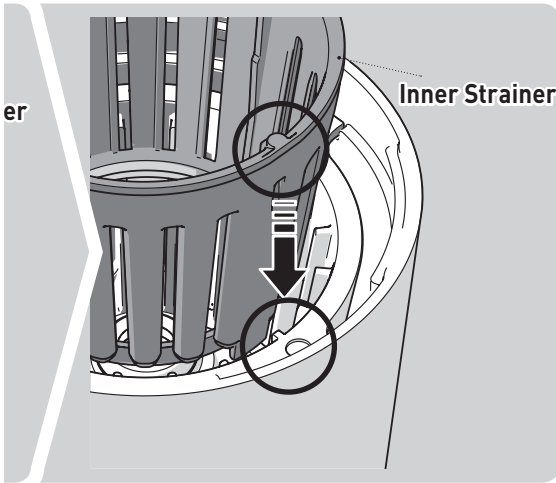

- 02** Place the inner strainer fit into the outer strainer in the chamber.
Match the binding point (⑤) of the inner strainer and the wings of the outer strainer (④) when putting the parts together.

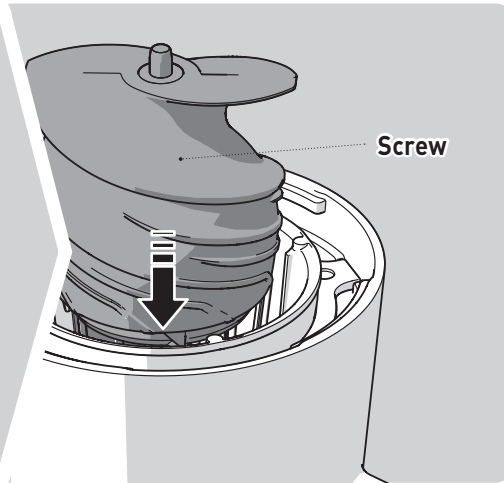

- 03** Place the screw in the assembly in 02.
Make sure the screw packing (⑥) is properly placed under the screw before putting the parts together.

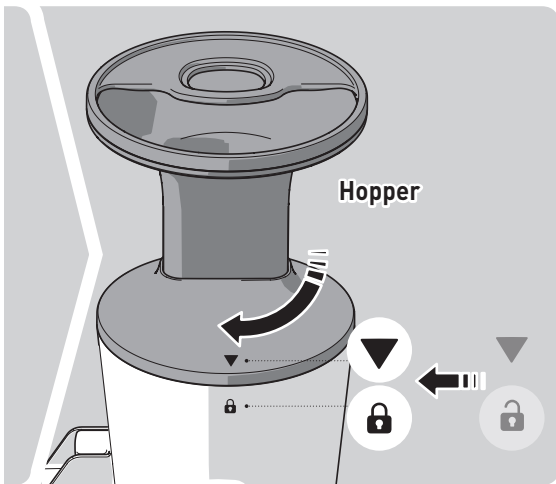

- 05** Turn the hopper clockwise up to the mark [🔒] on the chamber.
The hopper will not close if the inner parts are not assembled properly.

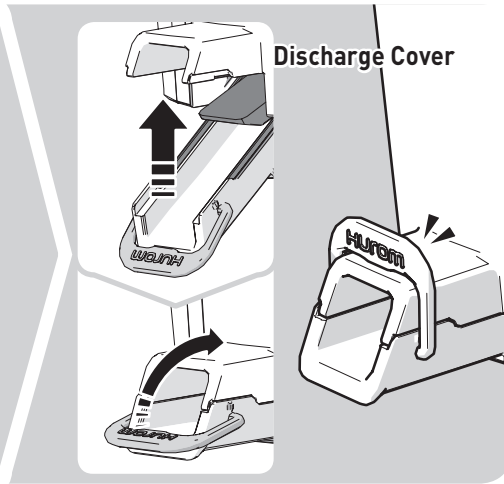

- 06** Make sure the discharge cover (①) of the chamber is properly fastened with the loop.
1. Close the discharge cover and fasten it with the loop.
 2. If the packing is not properly assembled or the lever is not properly closed, the lever may open or, juice may leak during extraction.

14 Assembling Ice Cream Chamber Set

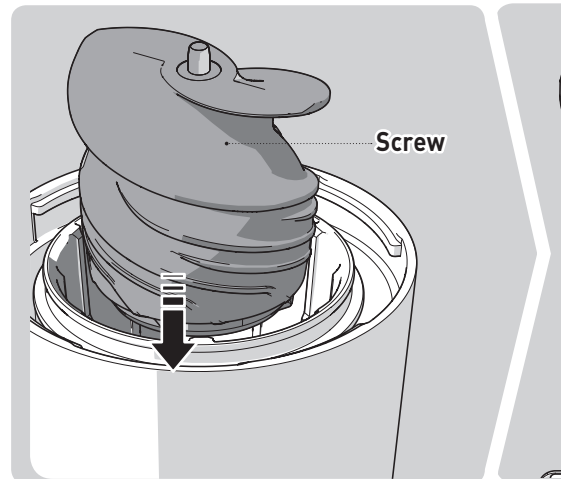
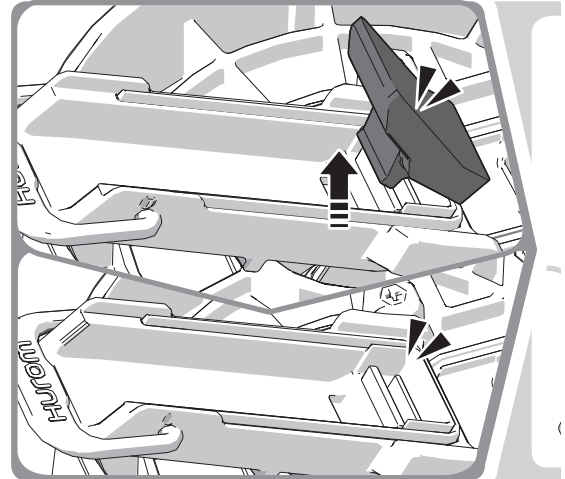
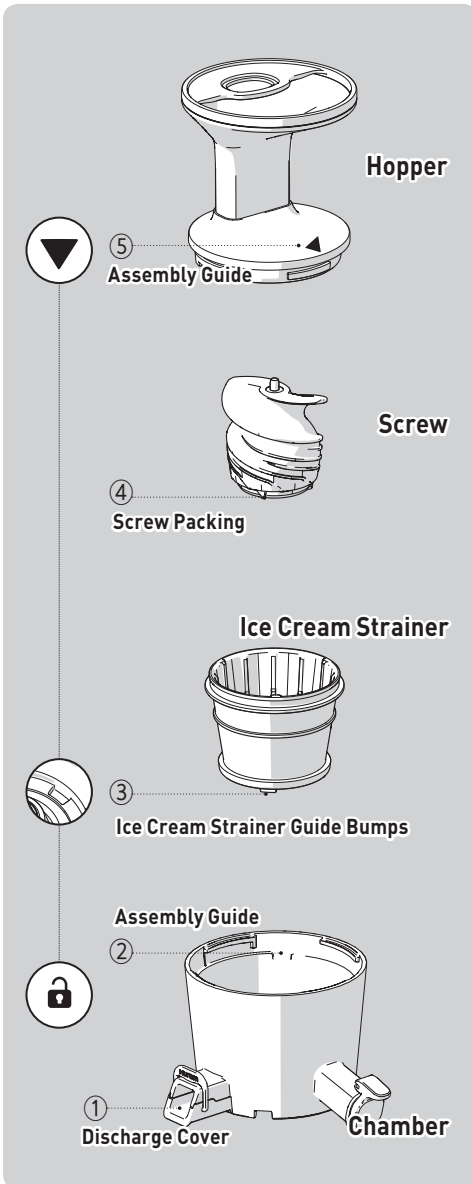

15

※ Assembly Guide with Main Body is in p16.

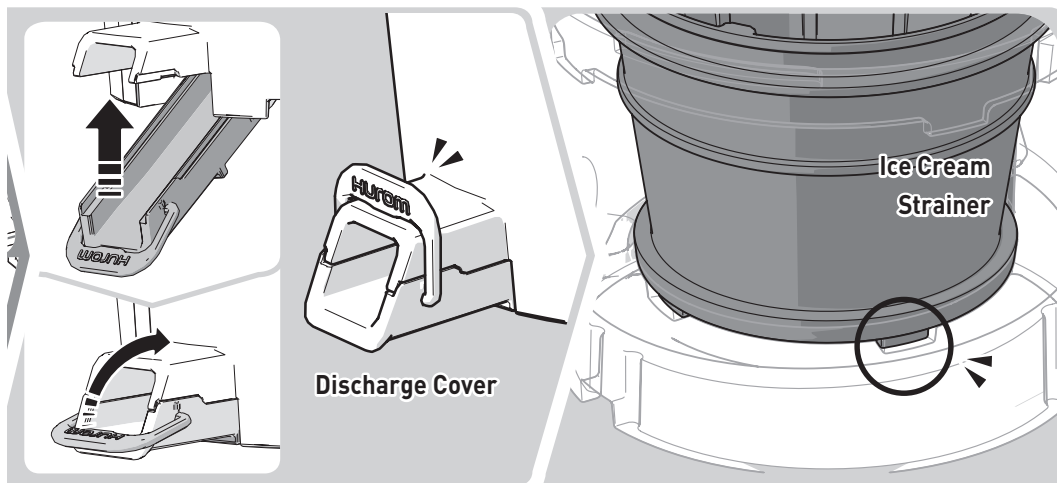

02 Make sure the discharge cover (①) of the chamber is properly fastened with the loop.

1. Close the discharge cover and fasten it with the loop.
2. If the packing is not properly assembled or the lever is not properly closed, the lever may open or, juice may leak during extraction.

03 Place the ice cream strainer in the chamber.

Wiggle the strainer left and right until the bump on the strainer fits the groove on the bottom of the chamber (③).

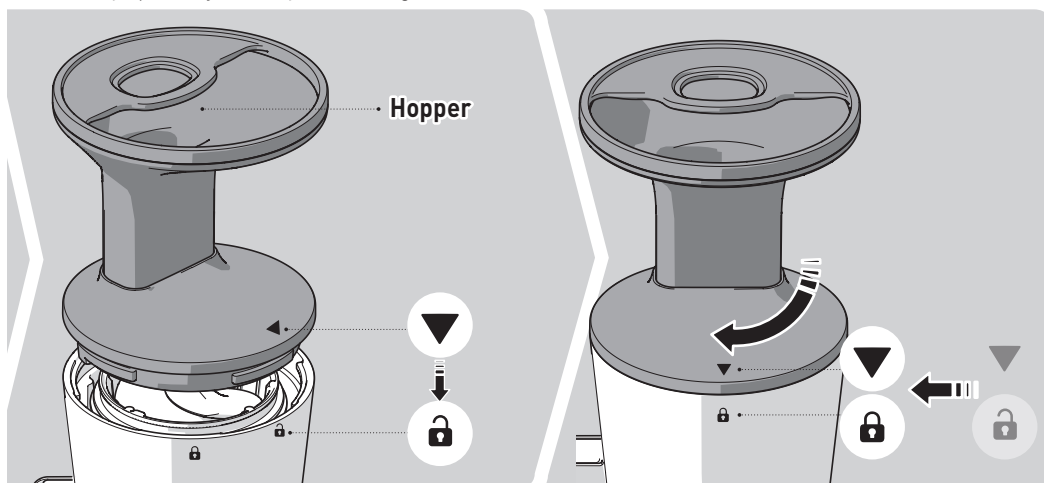

05 Match the mark [▼] (⑤) on the hopper and the mark [🔒] (②) on the chamber when putting the parts together.



The hopper will not close if the inner parts are not assembled properly.

06 Turn the hopper clockwise up to the mark [🔒] on the chamber.

The hopper will not close if the inner parts are not assembled properly.

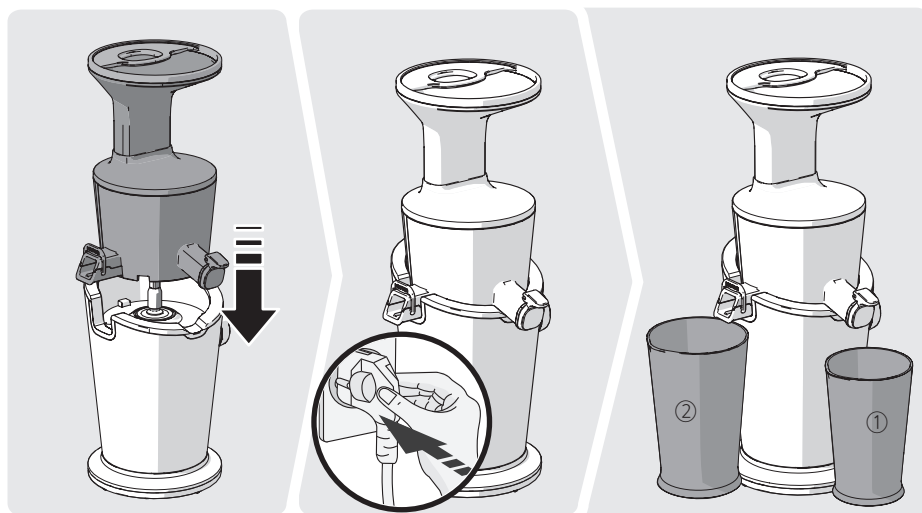
16 How to Assemble: Chamber Set and Main Body



- 01** Fit chamber set to main body.
- 02** Assemble the chamber set and main body first and then plug the power cord with your dry hand.
- 03**  Place the juice cup (①) and pulp cup (②) when you extract juice.
 Place the cup (②) under the pulp/ice cream outlet when you make ice cream.
Ice cream will come out of the pulp/ice cream outlet.

Check after Assembly!

- Check if you placed the Strainer of your choice**
The juice is not extracted smoothly if the strainer does not fit the ingredient.
- Check if the hopper is closed properly.** It may cause injury or failure.
- Check if the juice cap is closed.**
Keep it closed until you wish to pour out the juice.
- Check if the chamber set is assembled properly.**
- Ice cream comes out of the pulp/ice cream outlet.**
When making ice cream, remove the extraction packing.
- Make sure the extraction packing / seal packing / discharge cover loop are assembled properly.**
If the discharge cover is not closed properly, or the packing assembly is not correct, the discharge cover may open, or juice may leak during extraction.

17 Using Power Dial / When Screw Stops in Use

Using Power Dial

- ① Turn to right (clockwise) to 'Extract', set in the middle to 'Stop', and turn to left (counterclockwise) to 'Reverse'
- ② For safety, the machine will not stop instantly but slow down to a stop when you set the dial to Stop [●].
- ③ Reverse [REV] feature is active when you are holding the dial on [REV]. (Stops when you remove your hand.)

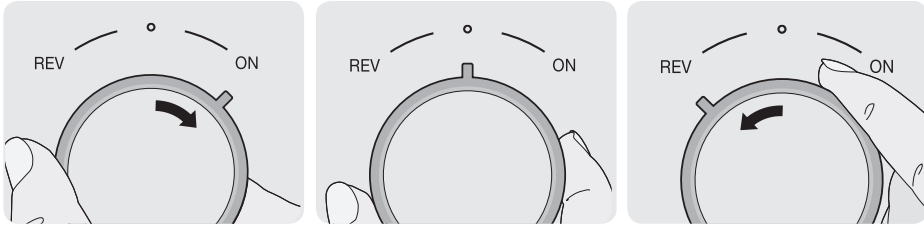

Screw Stops in Use

- * The screw may stop if you put ingredients too much or too quickly.
- * If the machine does not resume even after the following remedies, turn off the machine and contact Hurom Customer Center.

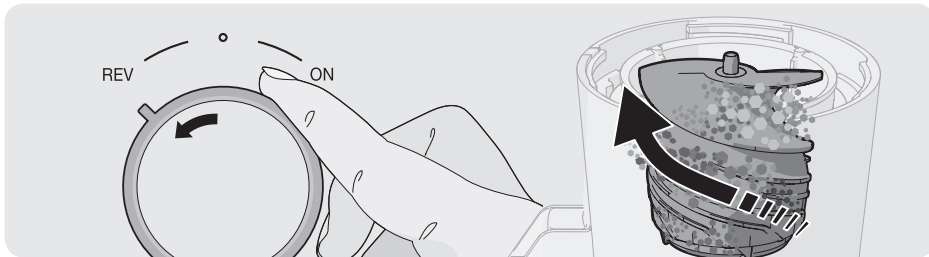

- 1** Turn the power dial to the direction of [REV] and hold it for 3-5 seconds (counterclockwise) and let it go. Repeat this 2-3 times.

The "Reverse" feature pushes the ingredients in the chamber upwards. The "Reverse" feature is active when you are holding the dial and stops when you remove your hand.

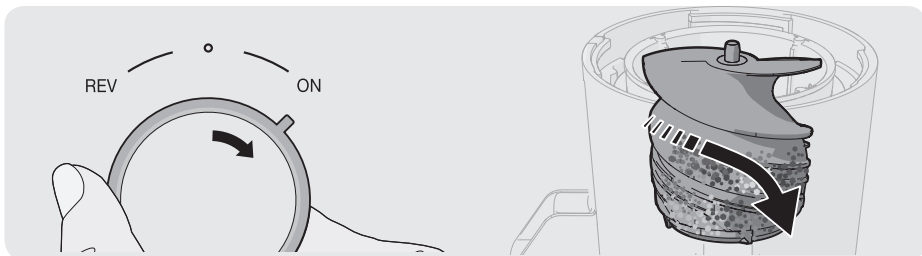

- 2** When the reverse motion comes to a complete stop, turn the power dial to the direction of [ON] (clockwise) to run.

When turning power dial to the direction of [ON] or [REV], make sure the screw comes to a complete stop first before turning the dial to the direction of your choice.

18 How to Use: Making Juice / Ice Cream



19

How to Use: Making Juice / Ice Cream

01 Make sure the discharge cover and juice cap of the chamber are closed properly.

- ① Even if the discharge cover is closed, pulp is discharged. The velocity and amount of discharge of pulp may differ according to the ingredients used.



When extracting juice: After making sure that the extraction packing and seal packing are assembled properly, close the discharge cover.



When making ice cream: Remove the extraction packing in the discharge cover.

- ① Do not remove the seal packing.

Turn the power dial to the direction of [ON] (clockwise).

- ### 02
- ① The 'click' sound heard when you turn the dial is the sound made when the chamber set and motor fit into each other.
 - ② Make sure the chamber set and main body are assembled properly.

Insert the ingredients into the inlet slowly.

- ### 03
- If the ingredient does not go down smoothly or is stuck at the inlet, use the pusher to push down the ingredients.**

- ### 04
- ① Do not use the hand or any other tool than the pusher. If not, it may lead to damage of product or personal injury.
 - ② If the machine stops in use due to overloading, turn the power dial to [REV](counterclockwise) to run in reverse direction.



When the juice begins to fill the chamber, open the juice cap to discharge juice.

- ### 05
- ① The chamber can be filled with juice quickly depending on the characteristic of the ingredients. Make sure the juice does not leak.
 - ② For ingredients that produce many bubbles such as cabbage and apple, keep the juice cap open during extraction.
 - ③ Ice cream is discharged through the ice cream outlet.

06 After extracting the last ingredients, run the machine in order of "30 seconds of normal rotation > 5 seconds of reverse rotation > 30 seconds of normal rotation."

- ① It slowly squeezes the ingredients to extract juice and needs some time enough to extract juice from the last ingredients.
- ② If the remaining pulp is removed by additionally running the machine after extraction, it is very convenient to remove the hopper and wash the parts.

07 When the extraction and discharge of pulp are completed, turn the dial to the direction of [O] (counterclockwise) to stop.

- ① For performance and safety, the machine will take 3-4 seconds to stop completely even when the power dial is at [O].

08 If there is any juice / ice cream left in the chamber, pour it by tilting the chamber set forward.

- ① For thick juice such as tomato juice, the juice might still remain inside the chamber.

20 Separating and Washing

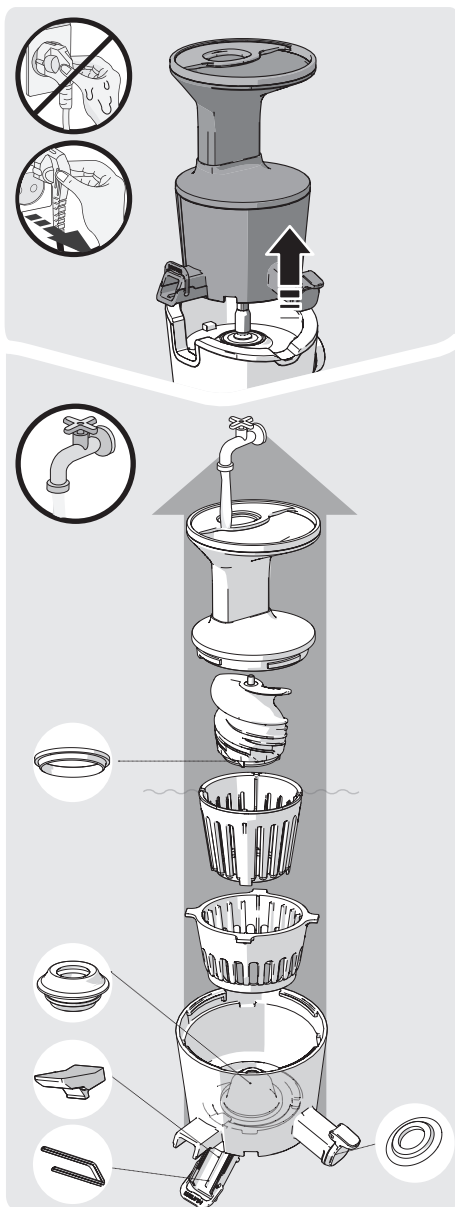

※ After the product has completely stopped operating, unplug the power cord with your dry hand. The motor will stop slowly even when you stop the machine. Separate the chamber set approximately 3 seconds after the machine comes to a complete stop.

- 01 Remove the chamber set from the main body. Twist the hopper to open and lift up in order to disassemble the unit.
- 02 Use a cleaning brush and wash the chamber set under running water.
- 03 For chamber, open the lift lever and juice cap to wash.
- 04 Clean the main body with dried towel or soft cloth.
- 05 In the case of packings made of silicon, remove and wash them after use. (Screw packing, Juice cap packing, Lift lever packing, Chamber packing)
- 06 Soak in the mixture of water, baking soda, citric acid, or vinegar for 30 minutes for sterilization.

※ If the unit is not cleaned immediately after use, the pulp may dry and stick to the unit. This will make disassembling and cleaning difficult and may also lead to performance degradation. Do not wash with hot or boiling water, an iron scrubber, abrasive material, sink solvents, or sharp cleaning tools. Do not put it in a dishwasher or dish dryer. After washing, thoroughly and naturally dry, and store in a clean area.

21 Disassembling and Washing Silicon Components

[Packing is a consumable component and replacement is recommended every 6 months ~ 1 year. You can purchase components through the Customer Center.]

Assembling and Disassembling the Screw Packing (if it is not assembled properly, the packing may be damaged)

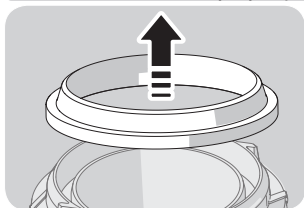

01 Flip over the screw and pull to remove it as if you are pinching it.

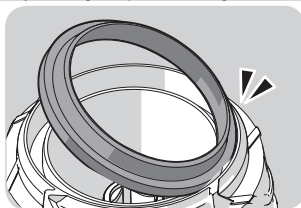

02 After washing, hold the packing in a way that the thin part of the packing faces outwards.

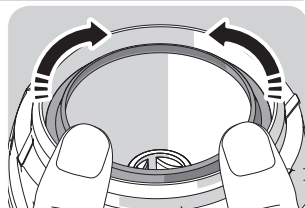

03 Place the packing on the bottom of the screw and push it in so that it will not fall off.

Assembling and Disassembling the Extraction Packing / Seal Packing (if it is not assembled properly, juice may leak)

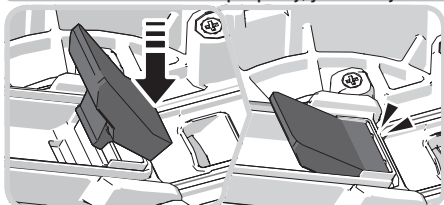

01 Hold the packing and pull it out smoothly.

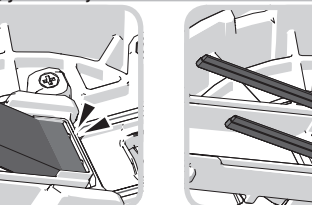

02 Insert one of the edges, and then put it down.

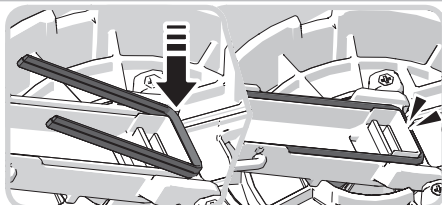

03 Insert the other parts and put them down firmly.

Assembling and Disassembling Chamber Juice Cap Packing (The juice will leak if not assembled properly.)

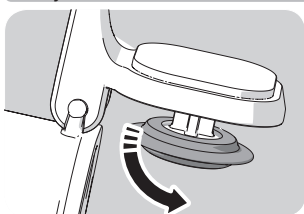

01 Remove the packing as though it is pulled inside out.

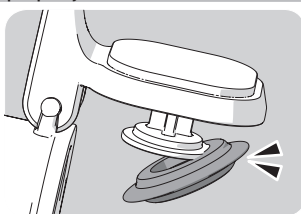

02 After washing, fit one side of the packing first like a hook.

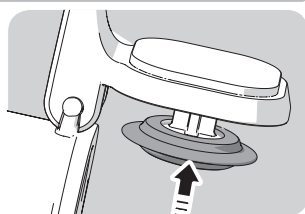

03 Fit the rest and push it in around the rim.

Assembling and Disassembling Chamber Packing (The juice will leak if not assembled properly.)

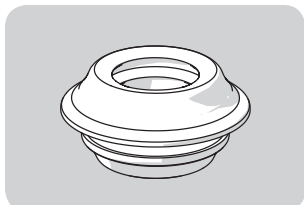

01 Remove the packing as though it is pulled inside out from one side.

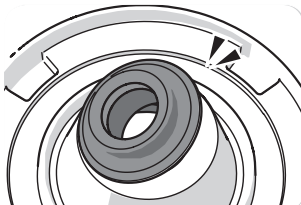

02 After washing, fit one side along with the chamber hole like a hook by checking the top and bottom sides of the packing.

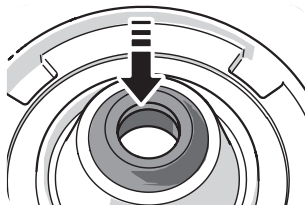

03 Push the rest of the packing in a way that no parts are folded.

22 Before Requesting for Repair

Check the following before asking for repair:

For follow-up service and any inquiry you may have while using the product, please contact our Customer Center, or homepage at <http://www.globalhurom.com>

Check the manufacturer's number or the number under the barcode when requesting for follow-up service or parts.

1. I hear 'click' sound when I start the machine.	When the screw fits into the motor, they produce this sound. This has not effect on use.	
2. I hear 'squeak-squeak' sound.	This is produced by the friction between screw packing and chamber. This is normal.	
3. The main body will not work on its own.	Make sure the chamber set and main body are assembled properly. Make sure the power is turned off when assembling / disassembling the product.	
4. Please align safety sensors.	Make sure they are assembled in accordance with the assembly guide. Make sure the power is turned off when assembling / disassembling the product.	
5. It will not work.	Check if the power cord is connected properly.	The machine may not work after a prolonged use (30 minutes or longer). The machine will work normally after the main body (motor) cools down.
	Check if the hopper is fit properly.	The machine will not work if the hopper is fit properly. It will work only when the lock icon on the chamber is matched with the triangle icon on the lid.
	Check if this product is properly assembled in the assembling order.	Refer to assembly guide P. 12-16
6. The appliance stops during normal operation.	Have you in heavy loads or large pieces of ingredients into the appliance?	Refer to p. 17 of the manual and follow the guideline for using [REV] button.
7. Screw has crack or scratch marks.	The screw has crack mark and scratch marks on the top. In addition to the straight molding marks on the top and sides of the screw, it also has a curved mark, all of which were made when molding the screw. This is normal and has no impact on use.	
8. The juice leaks from the outlet immediately after I insert the ingredients.	Depending on the ingredients used, the juice may come out of the pulp outlet. This is not a defect but is caused by the characteristic of the ingredient, and the leakage will stop when the machine runs. If the juice comes out persistently, contact the Customer Center.	
9. The juice leaks from the top of the main body.	Did you put too much ingredients? If the juice continues to leak from the top of the main body, contact our Customer Center for consultation.	If the input is greater than the chamber's capacity, the juice may leak between hopper and chamber. When you are extracting a large amount, make sure you open the lever and juice cap as often as necessary to discharge the content inside. If there is any water or juice on the main body, wipe it off immediately.
	Is the chamber packing assembled properly?	The juice will leak if the chamber packing is placed in a wrong direction or is not tightly placed. Check if the chamber packing is placed properly.
10. The hopper will not open.	There may be much pulp remaining inside.	If the remaining pulp is discharged by turning on the machine, or the machine is rotated in reverse for 10 seconds two or three times, the hopper will open smoothly.
	Did you put foreign or solid matter (hard seed such as the seed of persimmon)?	If foreign or solid matter is put into the chamber, running reverse can further the damage. Contact our Customer Center to request for repair service.
11. The chamber is shaking (when extracting).	The machine may wobble slightly by the kinetic energy of the motor of the main body. Extracting juice from various ingredients can cause various degrees of movements depending on the characteristics of the ingredients (hard or tough). This is a normal as the movement is caused by the rotating screw and is not considered as a trouble. It may seem that it is wobbling more severely when extracting juice from hard ingredients (i.e. carrot/potato/radish/beet/kohlrabi, etc.) compared to when extracting from soft and watery ingredients.	
12. Pulp is discharged even when the discharge cover is closed.	The pulp is discharged naturally even when you close the lever. Discharging amount and rate may vary depending on the ingredients used.	

23 Product Specifications / Warranty

Product Specifications

Product Name	Hurom Slow Juicer	Rated Operating Hour	Less than 30 minutes
Model Name	H-100S Series	Cord Length	1.4 m
Rated Voltage	230 - 240 V	Motor	Single-phase induction motor
Rated Frequency	50 Hz	Fuse	250 V 5 A
Rated Power Consumption	150W Energy efficiency is low at high rated power consumption(W).	Weight	5.7kg
RPM	43 rpm	Outward Dimension	W 210mm / L 224 mm / H 471 mm

Warranty

Product name	Customer name	Model name
Supplier	Date of purchase	Manufacture's serial number
Address		

Important: For better protection of your purchase, fill out and mail this form to a local distributor where you purchased the appliance and keep the original receipt.

This certifies that the Hurom Slow juicer is covered under warranty by **HUROM** to be free from defects in material construction and workmanship.

Hurom provides warranty for one (1) year from the date of purchase by the original purchaser. Coverage is valid only with proof of purchase from an Authorized Local Distributor. (No international warranty available)

This warranty does not apply to damages caused by accident, misuse, abuse, commercial use, alteration, failure to follow operating instructions, or damage caused by parts or service unauthorized by **HUROM**. Damages caused by transportation must be claimed with carrier. **HUROM** disclaims all responsibilities for consequential damages from incidental losses caused by use of this appliance.

Please check the bottom of your Hurom product for a sticker with a barcode. This barcode sticker helps verify a genuine Hurom product and identify the product manufacturing date. Hurom's manufacturer's warranty does not cover products with missing or damaged barcode stickers. Products are to be inspected upon receipt.

For service and assistance with technical difficulty, please contact our local Customer Service Center.

Manufacture : **HUROM**
 Hurom webpage : www.globalhurom.com

HUROM

MADE IN KOREA

Copyright© All Rights Reserved by HUROM

4DC010761_V.01